

COLLECTOR MOWER



REAR MOUNTED FLAIL COLLECTOR MOWER

To cut and collect grass, brush, ragwort, horse droppings, leaving a clean finish

The mower comes in 3 sizes:-

1.9m wide 2.3m wide & 2.7m wide

Powered by 1000 rpm PTO giving a rotor speed of approx 1250 rpm.

Heavy duty construction

Hydraulically operated collector box.

Can be easily converted to a standard mower by removing the collector box and fitting a back plate (supplied)

	WORKING WIDTH	TOTAL WIDTH	WEIGHT C/W COLLECTOR (APPROX)	QUANTITY OF FLAILS	MIN TRACTOR HP	COLLECTOR CAPACITY (APPROX)
UM19	1.9M	2.25M	780KG	16	60 HP	1.9 CUM
UM23	2.3M	2.60M	950KG	20	80 HP	2.3 CUM
UM27	2.7M	3.00M	1150KG	24	100 HP	2.7 CUM

Engineering & Hire Ltd

Specialist suppliers of waterways and grounds maintenance equipment

FLAILS DIRECT
.CO.UK

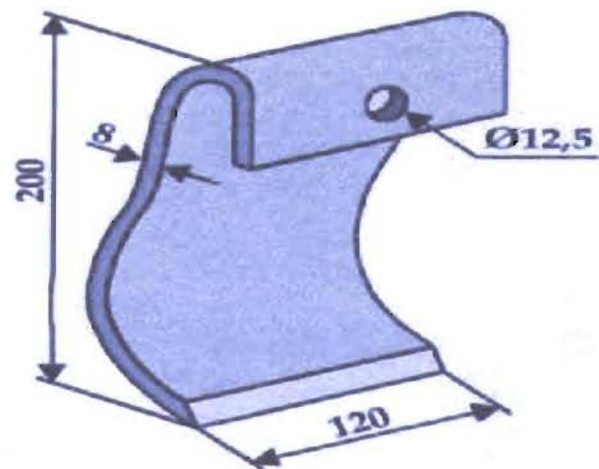
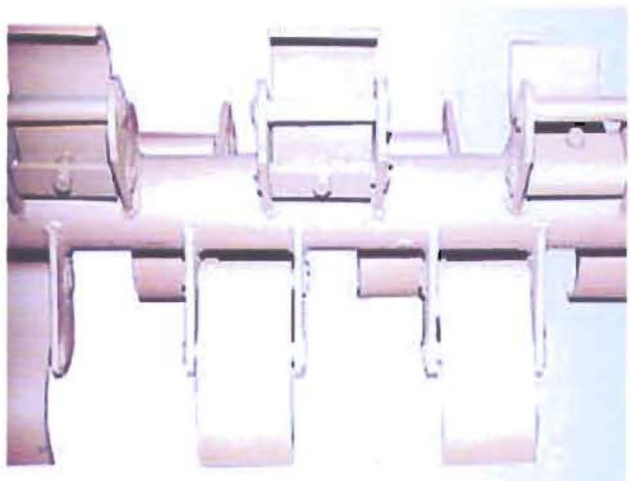

COLLECTOR MOWER FLAIL
2.05KG